

**APPLICATION FOR COLORADO STATE INCOME TAX CREDIT
FOR THE PRESERVATION OF HISTORIC STRUCTURES
(RESIDENTIAL PROPERTY – 2014 CREDIT)**

Pursuant to House Bill 14-1311 (CRS 39-22-514.5)

PART 2 -- FINAL APPROVAL

1. PROPERTY INFORMATION

Name of Property:

Address:

City/Town:

County:

Zip:

Name of Registered Historic District:

Property Type: Personal

Use of Property: Current:

After Rehabilitation:

Legal Description:

2. APPLICANT INFORMATION (taxpayer claiming the credit)

Name:

Type of Entity: Individual

Partnership: General Limited

Corporation: Regular Subchapter S

Limited Liability Company

Name of authorized company official (if applicant is not an individual):

Business address:

City/Town:

State:

Zip:

Telephone:

Residential address:

City/Town:

State:

Zip:

Telephone:

Taxpayer Identification Number (or Social Security Number):

If more than one taxpayer intends to claim the credit, include on a separate sheet the name, address and taxpayer ID number for all taxpayers intending to claim the credit.

3. OWNER INFORMATION, if applicant is other than owner (if owner is applicant, write "same")

Name:

Address:

City/Town:

State:

Zip:

Telephone:

4. PROJECT CONTACT

Applicant

Owner

Other (specify below)

Name:

Address:

City/Town:

State:

Zip:

Telephone:

5. PROJECT STARTING DATE:
PROJECT COMPLETION DATE:

6. PHOTOGRAPHS OF THE PROPERTY MUST BE INCLUDED (see instructions)

7. PROJECT COSTS

Itemized:

Total qualified costs:

Total project cost:

8. APPLICANT'S SIGNATURE

I hereby attest that I am the property's owner or a qualified tenant with a lease of five or more years, that all work on this project has been completed and executed according to the proposed project description as stated in Part 1 and approved by the Reviewing Entity, and that all itemized costs are allowable to claim for tax credits under CRS 39-22-514.5 (2)(k)(II). I hereby agree to allow representatives of the reviewing entity access to the property as may be necessary and reasonable for the final approval of the completed work.

Signature:



Date:

THE NYMAN HOUSE
5475 S MOHAWK ROAD
LITTLETON, CO 80123

DESCRIPTION OF REHABILITATION

UNDERSLAB DUCT WORK REPAIR

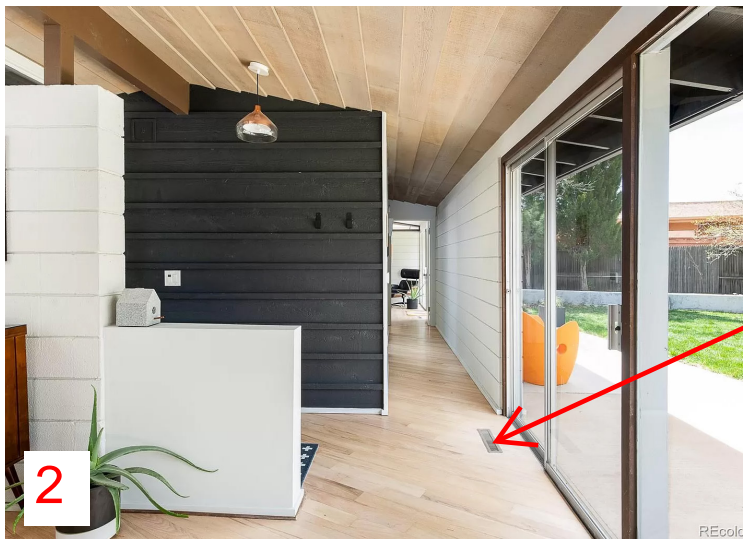

UNDERSLAB DUCT WORK REPAIR



WATER AND RUST
DAMAGE TO EXISTING
DUCTS

4



WATER AND RUST
DAMAGE TO EXISTING
DUCTS

5



DUCT RUSTED
THROUGH TO DIRT

6

UNDERSLAB DUCT WORK REPAIR
- COMPLETED WORK



RUSTED THROUGH
PORTIONS OF DUCT
SEALED WITH LIQUID
LATEX



DUCTS CLEANED AND
SEALED WITH LIQUID
LATEX

SKYLIGHT



EXISTING BROKEN SKYLIGHT



EXISTING BROKEN SKYLIGHT

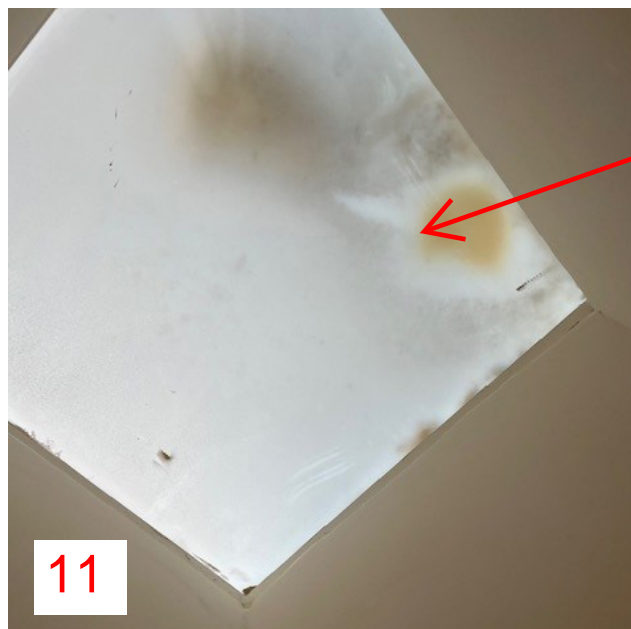

EXISTING DISCOLORATION AND DAMAGE TO SKYLIGHT FROM INTERIOR

SKYLIGHT -REPLACEMENT

DESIGN YOUR SKY



290 East 56th Avenue
Denver, CO 80216
303-296-9696
dalyteusa.com

Salesperson: _____
E-Mail: _____

CURB MOUNT SKYLIGHT WORKSHEET

Sold To: _____ Phone: _____ Fax: _____
Address: _____ City: _____ State: _____ Zip: _____
Contact: _____ Project/PO: _____ E-Mail: _____

QTY.	Outside Curb Dimension (OCD) See Below (In Inches)	Custom Dome Height 20-25% of smaller dimension if not specified	Other Notes
	24"x24" X		
	X		
	X		
	X		

Skylight Type: (Choose One)

- Standard Acrylic Dome
- Optional Acrylic Pyramid
6:12 Standard Slope
- Optional Flat
2:12 Minimum Slope
- Optional Custom Shape

Frame and Retainer Finish:
(Choose One)

- Clear Anodized
- Dark Bronze Anodized
- Custom Frame Finish:

Glazing: (Choose One)

- Standard Double Acrylic Dome**
 - Clear over Clear
 - Bronze over Clear
 - Clear over White
- Optional Single Acrylic Dome**
 - Clear Bronze White
- Optional:
 - Flat Insulated Glass Standard: Low-E Clear
 - Optional Bronze
 - Custom: _____
 - Flat Multiwall Translucent Polycarbonate Panel Standard: 16mm (5/8")
 - Clear Opal (White)
 - Bronze Custom: _____
- Optional:
 - 25mm (1") 3 Wall
 - 25mm (1") 7 Wall

OSHA Fall-Guard Protection:

- YES: Include Optional Custom OSHA Fall-Guard Protection.
- NO: OSHA Fall-Guards NOT Needed Because There Are Other Types of OSHA Fall Protection By Others.

Initial _____

Optional Dome Upgrade:

- High Impact (Outer Dome)
 - Clear White

Installation Supplies:

- Installation Kit
-3/4" Wide x 1/4" High x 35' Long Curb Gasket, and
-(20) #10x2" PPH SMS Installation Screws

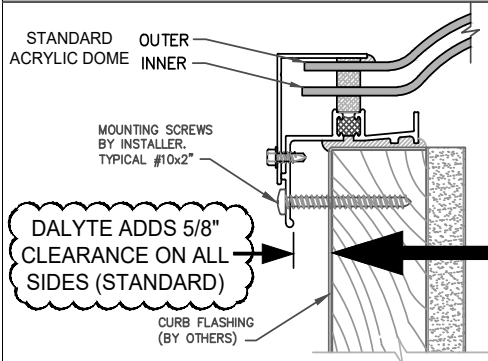

OUTSIDE CURB DIMENSION (OCD)

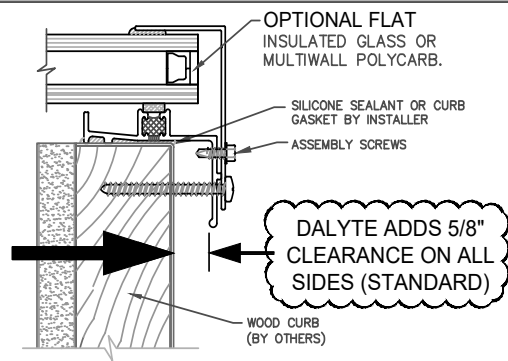

Approved By: _____

Date: _____

Specifications: Skylight as manufactured by DalYTE Denver Colorado. Units consist of an extruded aluminum 6063-T6. Inner frame (0.070") with a polyurethane thermal-break to reduce thermal transfer throughout the aluminum frame, and to minimize condensation in the interior frame. Outer frame (0.060") thick. Skylights are constructed to withstand 40 P.S.F. downward, and 20 P.S.F. outward loading and constructed to minimize air infiltration with provisions for adequate moisture weeping to exterior. Dome units shall consist of an acrylic thermal-formed free blown dome(s) in industry standard thickness as determined by overall size with peel-off protective film. Glass units shall be constructed of sealed insulated glass units with tempered outer lite, and laminated inner lite.

Note: Condensation is not a skylight defect, it is a result of atmospheric conditions inside and outside of the building. Skylights are designed to structurally account for expansion and contraction. Occasionally there may be audible popping noises especially with acrylic domes. All skylight glazing (transparent material) will have minor distortion especially when viewing at an angle. Tolerances are +/- 3/16".

DALYTE Skylights are not designed to support people. OCHA approved safety devices are to be used around skylight for personal safety. This worksheet will supersede all details on quotation - Please double check for accuracy.

v. 092222

SKYLIGHT -REPLACEMENT



NEW SKYLIGHT FROM
INTERIOR



NEW SKYLIGHT FROM
EXTERIOR

FIREPLACE DAMPER



APPROXIMATE
LOCATION OF
EXISTING BROKEN
DAMPER INSIDE
CHIMNEY FLUE



EXISTING CHIMNEY
CAP



BROKEN DAMPER
INSIDE CHIMNEY FLUE

FIREPLACE DAMPER

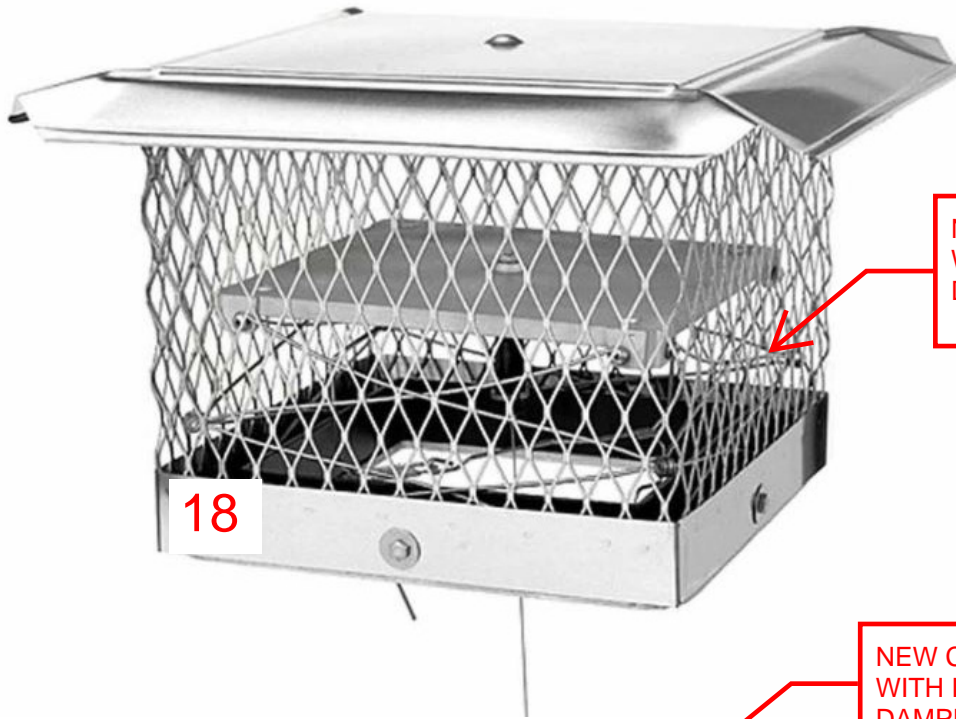

18

NEW CHIMNEY CAP WITH INTEGRATED DAMPER

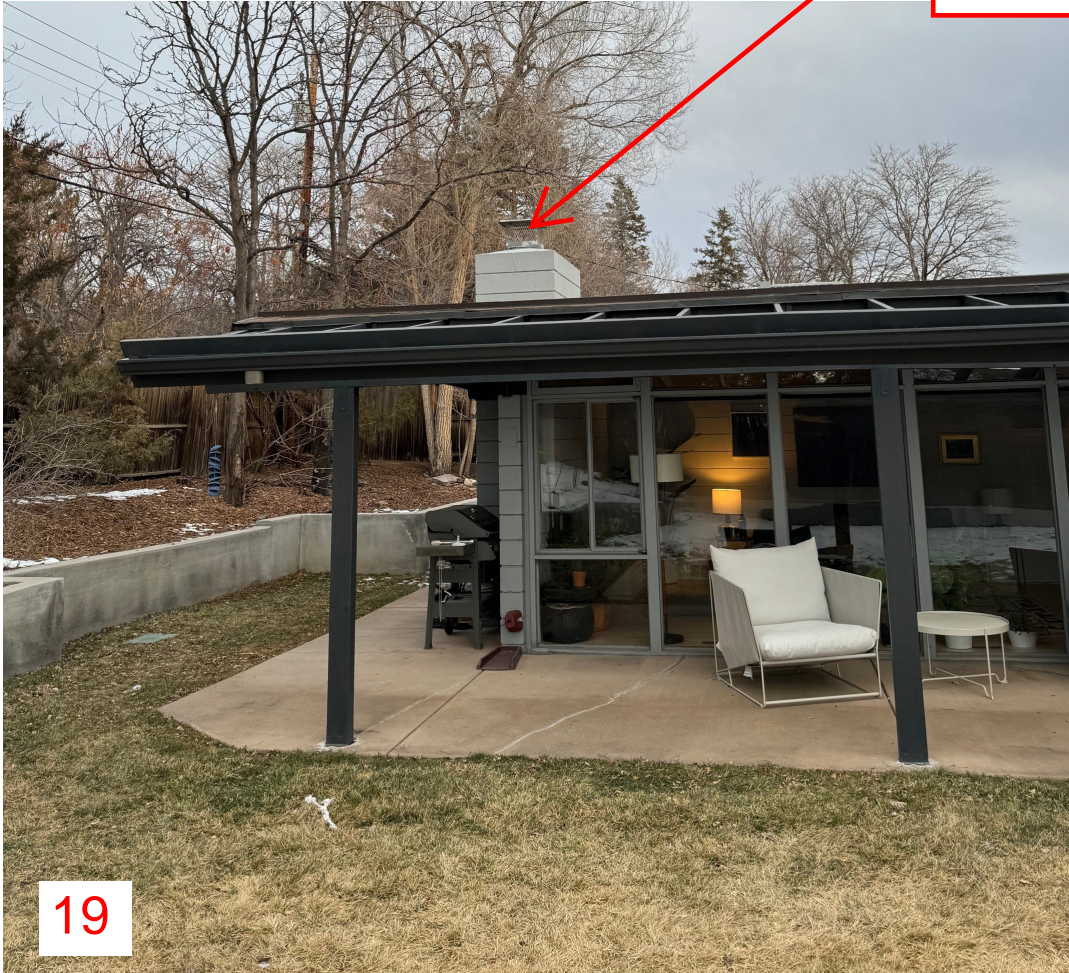

19



Planet Duct

Brent Forget
5475 S Mohawk Rd
Littleton, CO 80123

☎ (636) 346-8982
✉ bdforget@gmail.com

INVOICE	#9020
SERVICE DATE	Jun 13, 2023
DUE	Upon receipt
AMOUNT DUE	\$0.00

CONTACT US

3328 Adobe Court
Colorado Springs, CO 80907

☎ (719) 728-5111
✉ office@planetduct.com

INVOICE

Services	qty	unit price	amount
----------	-----	------------	--------

Duct Renovation - Duct Armor - Subterranean	1.0	\$6,900.00	\$6,900.00
--	-----	------------	------------

Approx 190 linear feet of ducting using about 20 gallons of Duct Armor.

Subterranean ducts can often deteriorate over time due to water, pests and settling or simply the materials used for the ductwork. When this happens the ductwork can become unusable or dangerous to the health of occupants.

Duct Armor creates an encapsulating liner that prevents any further deterioration of the duct system and allows you to use your underground ducts for many years to come. Service includes a camera scope of the system as well as applications of the liner roughly. There will be a smell like paint for a few days after applying the liner but once fully cured there is no odor.

Duct Cleaning before application is required and system being completely dry prior to application is required.

The client may need to "quikcrete" areas under the registers of bare earth is visible pryor to duct armor application.

Air Duct Cleaning - 1000 SF - 1799 SF included w Duct Armor	1.0	\$0.00	\$0.00
--	-----	--------	--------

Air duct system cleaning with a powerful "Negative Air Pressure" system. The cleaning is performed to the standard established by NADCA (National Air Duct Cleaners Association).

Residential Air Ducts should be cleaned every 3-5 year or after any remodel or restoration work has been done. Air duct cleaning should also be done immediately before a new furnace is installed.

We clean the supply and return runs and the trunk lines with pneumatic agitation tools while our powerful Vacuum pulls the dust, dirt and debris out of your system. We also clean the blower wheel , blower compartment and the return drop. Don't be fooled by low price coupon book amateurs. Hire the Professionals at Planet Duct. Our pricing is based off square footage, not vents. So there is no need to count them. (see additional service items if you have more than 1 furnace or if your furnace is located in an attic or crawl space).

Work outside of the Colorado Springs Metro area may incur a trip charge.

Dryer Vent Cleaning - Dryer Vent Cleaning with Air Duct Cleaning	1.0	\$0.00	\$0.00
---	-----	--------	--------

ONLY CHOOSE THIS OPTION IF WE ARE ALSO DOING WHOLE HOUSE AIR DUCT CLEANING AT THE SAME TIME.

Cleaning out your clothes dryer vent will make your dryer, dry clothes faster and make your dryer last longer. Cleaning your dryer vent will also reduce the risk of having a dryer vent fire. Clogged dryer vents are the #1 cause of home fires in the Unites States.

If your clothes are taking longer to dry, you should have the vent cleaned.

If the laundry room is getting very hot when you dry clothes, you should have the vent cleaned

If you notice a burning smell when you are drying clothes, you should have the vent cleaned immediately.

If you see allot of lint sticking out of the exhaust vent outside, you should have the vent cleaned.

If you cant remember that last time the vent was cleaned, you should have the vent cleaned.

Total **\$6,900.00**

Payment History

Jun 13	Tue 4:56pm	Check	\$6,900.00
--------	------------	-------	------------

Stronger Than The Vacuum Of Space !

Have your HVAC filters delivered to your door

and get automatic filter change email reminders.

Just go to: <https://filterfetch.com/contractor-link/CD95>

Cancellation policy: We do not cancel due to weather unless the roads are treacherous.

24 hours notice is required for cancellation or rescheduling your air duct cleaning or Aerosealing appointment. If an air duct cleaning or Aerosealing appointment is cancelled or rescheduled with less than 24 hours notice, a \$200 reschedule fee will be applied and prepayment will be required prior to service being rescheduled.







































ACKNOWLEDGEMENT

DESIGN YOUR SKY



P-15020

9/6/2023

BRENT FORGET

To: ~~Chris Davis~~
 BOSS Architecture
 5475 Mohawk Rd
 Littleton CO 80123-2940
~~303-377-6322~~ *636-346-8982*
 chris@bossarch.com

From: Garrett Gill
 AiA Industries, LLC dba DALYTE
 GGill@DalyteUSA.com

Project:	Brent Forget			
Description:				
PO Number	Terms	Credit Card	Shipping Method:	Delivery

Quantity	Item	Unit Price	Total Amount
1	Installer	\$225.00	\$225.00
1	Curb Mount Skylight - Acrylic 24" x 24" Outside Curb Dimension Double Dome Bronze/Clear Clear Anodized Thermally Broken Aluminum Frame	\$289.25	\$289.25
1	Installation Kit for Curb Mount Skylights	\$25.00	\$25.00
Subtotal			\$539.25
Sales Tax			\$25.15
Quote Total			\$564.40

DALYTE
 290 E 56TH AVE
 DENVER CO 80210
 800-748-2036

09/06/2023
 Merchant ID: *****0889
 Terminal ID: 1434615
 14:17:54

Credit Sale:
 Transaction #: *****7360
 Card Type: Manual
 Account: *****7360
 Entry: 5

Amount: USD\$564.40

STAN: 1139
 Host Ref. Number: H89150
 Auth. Code: 5
 Batch Number: 295
 Response: APPROVAL
 CVD Response: 2 - Zip Code Matches
 NETWORK: Match - Values match
 MASTERCARD

Retain this copy for statement
 validation
 CUSTOMER COPY



Chimney Sweeps of America
 5161 Ward Road Unit #8 Wheat Ridge, CO 80033
 Phone: 303-973-7376 Fax: 303-227-7641
info@chimneysweepsofamerica.com

Invoice
WO 60134

Customer Information

Brent Forget
 5475 S Mohawk Rd
 Littleton, CO 80123

Phone: 636-346-8982

Work Date	Arrive	Team
1/24/2024	2:00 PM	Tim's Truck

Summary: Install 13x13 Lock Top Damper

All pictures (current conditions, final pictures, & recommended repairs) are located on the last page of this invoice.
Inspection Report and/or Notes from the job are located directly below the Services/Products section.

Service/Product	Price	Qty	Amount
13x13 Lock Top II Damper Fits: 9x9 to 12.5x12.5 ID Cross Sectional Area: 100 sq. in. Includes EZ Open Damper Handle	\$775.00	1.00	\$775.00
Credit Card Transaction Fee 3% Credit Card Transaction Fee *Can be removed if paying with check or cash.*	\$23.25	1.00	\$23.25
		Subtotal	\$798.25
		Tax	\$0.00
		Total	\$798.25

Payment via No Payment, ending #, in the amount of \$0.00, was received on 1/24/2024.

Inspection Report and/or Notes:

A new 13" x 13" LockTop damper system was installed today. It acts as a flue cap and damper system all in one. It sits on top of the flu tile and it has a stainless steel wire that runs down the flu tiles into the fireplace with a new damper handle has been installed on the fireplace wall. It's bolted into the wall with two bolts. The damper on top seals itself when closed so it's airtight and prevents weather from accessing the fireplace.

Payment Terms: Non-refundable 50% required for booking and ordering parts. Remainder is due upon completion.

****PAYMENT OPTIONS ARE AVAILABLE: 12 MONTH SAME AS CASH OR 5 YEAR 6.99% LOW MONTHLY PAYMENT.** Please reply back to this e-mail or call for more information and qualification**

Why choose Chimney Sweeps of America? All of our technicians are nationally certified by the Chimney Safety Institute of America. We are NFI certified specialists and installers in Gas, Wood, and Pellet fueled appliances and are the only company with multiple NFI Master Hearth Professionals on staff. We are a trusted name that has been serving the Denver area since 1982, a local family owned and operated business. We are annual service award winners with Angie's List and Home Advisor and have a A+ standing with the BBB. We are licensed, insured, and bonded and can provide any documentation when needed. We can provide referrals if requested as we've installed thousands of hearth and free standing appliances. We are proud members of the HPBA, NFPA, and the National Chimney Sweep Guild. We regularly continue our education to keep up with the ever changing codes and innovations in our industry to provide the most up to date and accurate information, products, and options for repairs and updates. Safety and education are our priorities and our customers are our passion.

Customer Signature: _____
 Date: 1/24/2024

I hereby acknowledge and agree to all payment terms and conditions listed above.

Please fill out our [CUSTOMER SURVEY](#) as we greatly value your feedback. We appreciate your time and are constantly striving to meet and exceed your expectations.



Chimney Sweeps of America – 303-973-7376 – www.chimneysweepsofamerica.com

Photos After

